

**STAYFLEX® CORROSION CONTROL
AND THERMAL INSULATION SYSTEM**
INSTALLED IN PRE-ENGINEERED STEEL BUILDINGS
PROVIDES LOWEST COST CONSTRUCTION METHOD
FOR CORROSIVE AND WET ENVIRONMENTS



Thirty-year case histories validate the ability of the Stayflex® System, used in both new and existing pre-engineered steel buildings, to provide the lowest initial and long-term operating costs in corrosive and wet environments.

When specifying buildings having corrosive and wet environments, two primary objectives exist:

1. Provide a building that has the lowest construction and long-term maintenance costs.
2. Provide options to accommodate initial and future budgets.

This document summarizes how the Stayflex® Corrosion Control and Thermal Insulation System in conjunction with pre-engineered steel buildings enables specifiers to accomplish these two objectives in a manner not possible with any other building technology.

Steel buildings are very cost-effective compared to alternative construction methods such as concrete buildings but often corrode rapidly in corrosive and wet environments, discouraging its use by specifiers for projects having these types of environments.

Uninsulated or poorly insulated steel roofs, siding and structural steel can result in the formation of condensation which significantly accelerates corrosion of steel building components.

Elimination of condensation in pre-engineered steel buildings in corrosive and wet environments is critical for long-term, cost-effective performance. Important issues:

1. Condensation is the change of the physical state of water vapor from the gas phase into liquid phase. Condensation (dew) will form when the temperature of the substrate is cooler than the temperature of the water vapor (humidity) present. Dew point is the temperature at which water vapor condenses into visible drops of water.

The boxed area in the body of **Table 1** shows typical dew point temperatures in buildings having corrosive and wet environments. For example, a building with an interior air temperature of 75° F (from far left hand Temperature column) having 65% relative humidity (from Percent relative humidity line of the table) would reach the dew point (temperature at which condensation will form) when the exterior air temperature is 62° F.

2. Condensation on steel building components accelerates corrosion, particularly if chemical vapors are also present. Complete section loss and structural failure of roof purlins and decking has occurred in less than five years after construction when condensation is not controlled.
3. Over time, condensation formed on the interior surfaces of metal roofs, siding, purlins and girts will infiltrate (saturate) commonly used thermal insulation materials such as fiberglass batt insulation. The presence of moisture, which increases the insulation's thermal conductivity, can lead to near total loss of thermal efficiency.
4. Condensation is eliminated by:
 - A. Installing sufficient thickness of insulation to keep insulation and steel surfaces above the dew point.
 - B. Installing a seamless insulation system to avoid thermal breaks.
 - C. Installing a seamless, effective water vapor barrier to the warm, exposed side of the insulation to prevent water vapor from entering the insulation.

Table 2 summarizes the uniqueness of the Stayflex® System compared to alternative thermal insulation systems for pre-engineered steel buildings. Only the Stayflex® System has the necessary performance attributes required for long-term, cost-effective performance in corrosive and wet environments.

Fiberglass blanket insulation commonly used in metal building construction to save energy or stop condensation has two significant limitations:

1. As shown on **Drawing 1**, the insulation between the roof and purlins is compressed. This compression reduces its thermal efficiency, resulting in the formation of condensation. Condensed water and chemical vapors are deposited and trapped in the lower horizontal lip of the purlins, accelerating corrosion.
2. Moisture and chemical vapors infiltrate the fiberglass insulation at the seams reducing its thermal efficiency. As moisture builds up within the insulation, the additional weight causes the insulation to sag, opening the seams between the fiberglass blankets. This further exposes the roof deck to the chemical and moisture vapors, accelerating the corrosion of the deck.

In an attempt to eliminate water vapor intrusion associated with cellulose, mineral wool and glass fiber insulation materials, reinforced polyester resin (FRP) and stainless steel liner panels fastened to the bottom of the purlins and girts have been tried and evaluated. While conceptually encouraging, actual installations have shown it is virtually impossible to obtain vapor tight seals by various sealing and caulking methods, particularly where the panels butt against structural steel members and around equipment protruding through the panels. Even if good initial seals are achieved, moisture and chemical exposure, building movement and vibration eventually cause opening of the joints, allowing the passage of water and chemical vapor. This leads to the formation of condensation behind the liner panels. The condensation is now trapped, accelerating corrosion. Structure failure can occur since the extent of corrosion can not be seen or detected

Sprayed polyurethane foam insulation is a good candidate but can only be used safely and in compliance with building codes if it is covered with a fire-resistant surface. The Stayflex® 2505 Thermal Barrier Coating is the only polymer, fire-resistant coating for sprayed polyurethane foam that is code compliant. Stayflex® 2505 is made with the same generic polymers as those used to make other chemical resistant FRP products such as corrugated roofing and siding, grating, tanks and piping, having excellent performance for over 50 years in corrosive and wet environments. Typically, other fire protective products for sprayed polyurethane foam are fibrous or cementitious. Their high permeability prevents their long-term performance in wet environments and such applications are actually discouraged by their manufacturers.

As shown on **Drawing 2**, the Stayflex® System encases all steel surfaces and provides unique performance by:

1. Insulating all steel to prevent condensation.
2. Eliminating horizontal surfaces of purlins.
3. Providing an excellent chemical and fire resistant surface.
4. Providing a highly impermeable barrier to block air, moisture and chemical vapors thus preventing further steel corrosion and eliminating future steel replacement.
5. Strengthening the roof to improve longevity and safety.

Additional performance benefits provided by the Stayflex® System include:

1. Improved wind resistance.
2. Improved live load capabilities.
3. Reduced sound transmission.

The most cost-effective construction method that will provide long-term performance in corrosive and wet environments is to construct a pre-engineered steel building with the Stayflex® System applied to all the exposed interior surfaces of the building. **Table 3** indicates construction costs for a 30,000 square foot pre-engineered building with a 1”– 4” thickness of the Stayflex® System should be approximately \$32.00 - \$36.00 per square foot of floor area.

If funds cannot be made available to encase all surfaces at the time of initial construction, the most prudent first step is to install the Stayflex® System on the underside of the roof deck and supporting structural steel in direct contact with the roof deck since these components usually are the most susceptible to condensation and corrosion. Other steel surfaces can be encased later as funds become available.

Table 4 illustrates the thermal efficiency of the Stayflex® System, which reduces energy consumption up to 98% compared to an uninsulated steel building.

Preferred Solutions, Inc. welcomes the opportunity to discuss technical, cost and case history information with building owners, architects and engineers to develop designs and specifications for constructing the lowest cost, highest performance buildings for harsh environments.

Dew Point Temperatures

TABLE 1

Percent relative humidity

Interior Temp. °F.	Percent relative humidity																		
	10	15	20	25	30	35	40	45	50	55	60	65	70	75	80	85	90	95	100
5	-35	-30	-25	-21	-17	-14	-12	-10	-8	-6	-5	-4	-2	-1	1	2	3	4	5
10	-31	-25	-20	-16	-13	-10	-7	-5	-3	-2	0	2	3	4	5	7	8	9	10
15	-28	-21	-16	-12	-8	-5	-3	-1	1	3	5	6	8	9	10	12	13	14	15
20	-24	-16	-11	-8	-4	-2	2	4	6	8	10	11	13	14	15	16	18	19	20
25	-20	-15	-8	-4	0	3	6	8	10	12	15	16	18	19	20	21	23	24	25
30	-15	-9	-3	2	5	8	11	13	15	17	20	22	23	24	25	27	28	29	30
35	-12	-5	1	5	9	12	15	18	20	22	24	26	27	28	30	32	33	34	35
40	-7	0	5	9	14	16	19	22	24	26	28	29	31	33	35	36	38	39	40
45	-4	3	9	13	17	20	23	25	28	30	32	34	36	38	39	41	43	44	45
50	-1	7	13	17	21	24	27	30	32	34	37	39	41	42	44	45	47	49	50
55	3	11	16	21	25	28	32	34	37	39	41	43	45	47	49	50	52	53	55
60	6	14	20	25	29	32	35	39	42	44	46	48	50	52	54	55	57	59	60
65	10	18	24	28	33	38	40	43	46	49	51	53	55	57	59	60	62	63	65
70	13	21	28	33	37	41	45	48	50	53	55	57	60	62	64	65	67	68	70
75	17	25	32	37	42	46	49	52	55	57	60	62	64	66	69	70	72	74	75
80	20	29	35	41	46	50	54	57	60	62	65	67	69	72	74	75	77	78	80
85	23	32	40	45	50	54	58	61	64	67	69	72	74	76	78	80	82	83	85
90	27	36	44	49	54	58	62	66	69	72	74	77	79	81	83	85	87	89	90
95	30	40	48	54	59	63	67	70	73	76	79	82	84	86	88	90	91	93	95
100	34	44	52	58	63	68	71	75	78	81	84	86	88	91	92	94	96	98	100
105	38	48	56	62	67	72	76	79	82	85	88	90	93	95	97	99	101	103	105
110	41	52	60	66	71	77	80	84	87	90	92	95	98	100	102	104	106	108	110
115	45	56	64	70	75	80	84	88	91	94	97	100	102	105	107	109	111	113	115
120	48	60	68	74	79	85	88	92	96	99	102	105	107	109	112	114	116	118	120
125	52	63	72	78	84	89	93	97	100	104	107	109	111	114	117	119	121	123	125

Comparison of Thermal Insulation and Corrosion Control Systems For Pre-engineered Steel Buildings having Corrosive and Wet Environments

TABLE 2

Installation on exposed, interior surfaces of steel siding, roofing and structural members

	Spray-applied Systems			
	Fiberglass blanket with white vinyl surface	Cellulose, mineral wool, glass fibers	Polyurethane foam systems	
			with cementitious, fibrous fireproofing surface	with Stayflex® 2505 Thermal Barrier Coating
<u>Insulation material:</u>				
“R” value per inch	4.0	2.9-3.4	6.1	6.9
Seamless to prevent heat and cold loss through joints	No	Yes	Yes	Yes
<u>Protective surface:</u>				
Thickness	0.10”	None	1/2”	.062 (1/16”)
Permeability to water vapor (lower rating= more resistance)	0.8	>1 (not recommended by manufacturers for wet environments)	>1 (not recommended by manufacturers for wet environments)	0.09
Seamless to prevent water vapor from entering through seams	No	Yes	Yes	Yes
Chemical resistance	Fair	Fair	Fair	Excellent
Highly resistant to punctures and cuts	No	No	No	Yes

TABLE 2 continued on next page

TABLE 2 (con't)

Installation on exposed, interior surfaces of steel siding, roofing and structural members

	Spray-applied Systems			
	Fiberglass blanket with white vinyl surface	Cellulose, mineral wool, glass fibers	Polyurethane foam systems	
			with cementitious, fibrous fireproofing surface	with Stayflex® 2505 Thermal Barrier Coating
<u>Complete insulation system:</u>				
Lowest annual costs	No	No	No	Yes
Expected service life in humid environments before performance is reduced	1-3 Years	1-3 Years	1-3 Years	30+ years
Able to control steel corrosion by being a barrier to air, moisture and chemical vapors	No	No	No	Yes
Direct adherence to all steel surfaces	No	Yes	Yes	Yes
Able to maintain original thermal resistance necessary to prevent condensation and heat/cold loss	No	No	No	Yes
Adds strength to roofs and siding	No	No	Yes	Yes
Can be frequently and easily power washed to maintain good appearance	No	No	No	Yes

DRAWING 1

Corrosion stages of roofs and purlins when pre-engineered steel buildings are used in corrosive and wet environments.

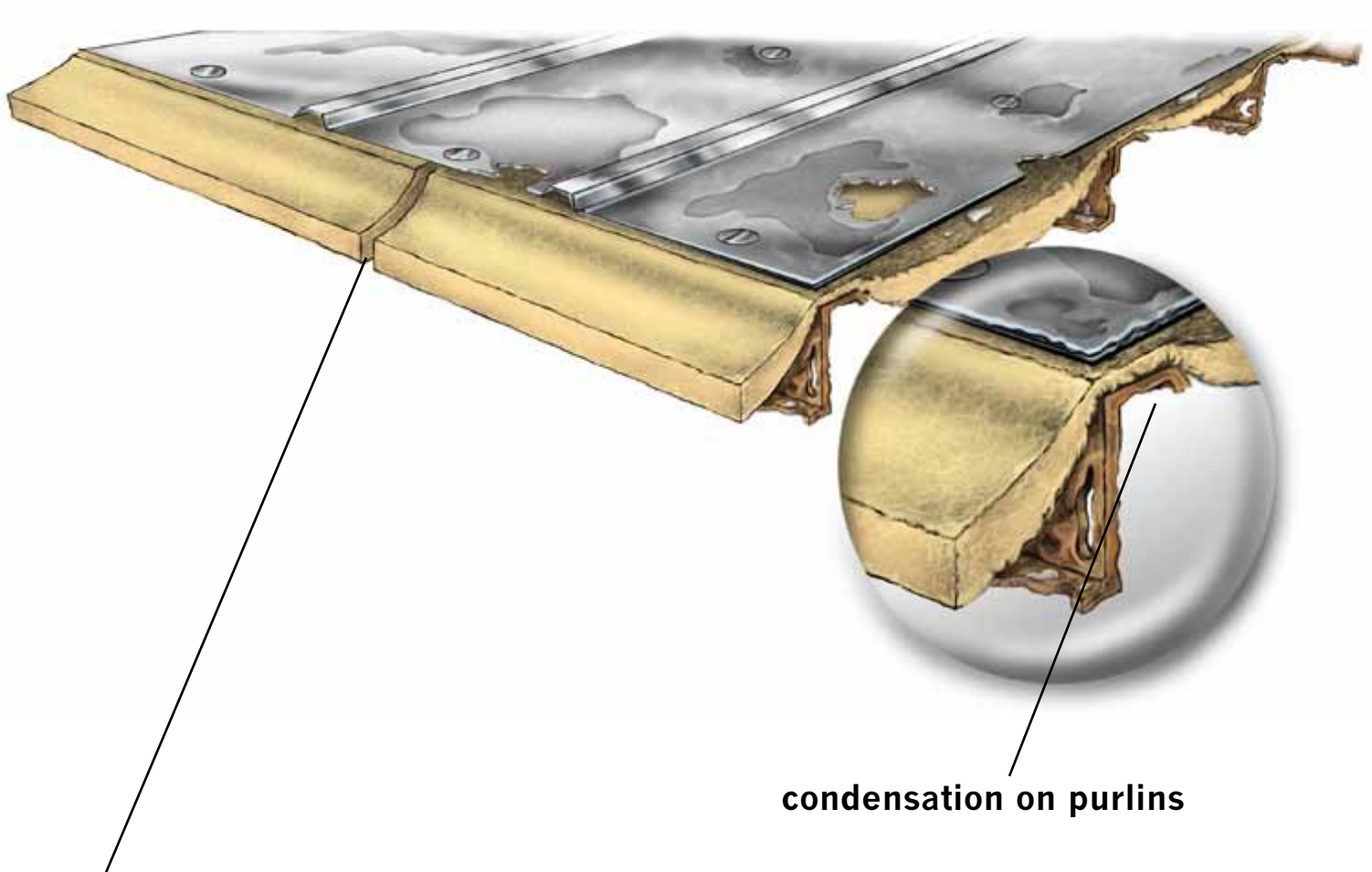

Air spaces and seams between fiberglass blanket insulation permit chemical and water vapors to infiltrate and condense on metal roof, causing corrosion and saturation of insulation. Compressed insulation above purlins causes condensation on purlins which accumulates in the lower flange, resulting in corrosion and structural failure.

DRAWING 2

Stayflex® Corrosion Control and Thermal Insulation System encases all surfaces of steel roof, structural steel and purlins to eliminate condensation and corrosion

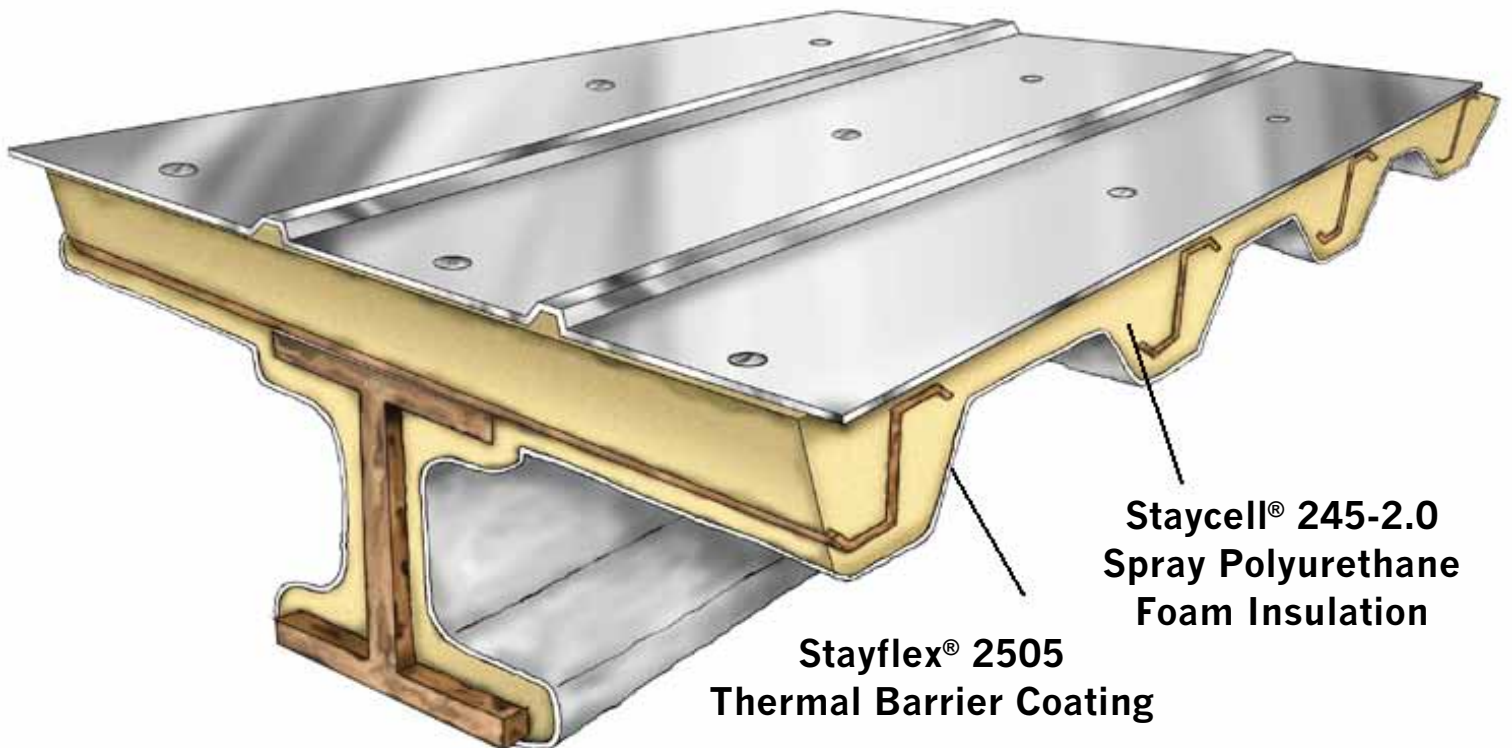

Estimated Installed Prices
Stayflex® Corrosion Control and Thermal Insulation System
installed in 30,000 square foot, pre-engineered steel building

TABLE 3

Building Shell with Foundation				
Stayflex® System	Stayflex® System Thickness*			
	1"	2"	3"	4"
Roof and purlins	\$210,000	\$240,000	\$270,000	\$300,000
Walls and girts	\$80,000	\$90,000	\$100,000	\$110,000
Columns and beams	\$70,000	\$70,000	\$70,000	\$70,000
Pre-engineered steel building	\$360,000	\$400,000	\$440,000	\$480,000
30,000 square foot steel building**	\$600,000	\$600,000	\$600,000	\$600,000
Total cost				
Pre-engineered steel building with Stayflex® System	\$960,000	\$1,000,000	\$1,040,000	\$1,080,000
Cost per square foot of floor	\$32.00	\$33.33	\$34.67	\$36.00

* Thickness on underside of roof and interior of siding; 1" on all other surfaces

** Estimated costs for the following steel building:

Dimensions: 100 feet wide; 300 feet long; 14 foot eave height

Roof slope: low-profile, 1 in 12 rise

Roof live load design: 20 pounds per square foot

Steel sheeting: 26 gauge galvanized on ends, sides and roof

Purlins: 8" depth, 60" on center

Girts: 8" depth, 48" on center

Primary steel columns and beams: 25' on center

Foundation: 4" concrete floor with reinforcing mesh and 2" sand fill

Window area: 2% of floor area

Wiring: Basic

Lighting fixtures: Minimum

Gravity vents: One medium vent per 2,500 square feet of floor area

**Energy Savings Provided by Stayflex® Corrosion Control and Thermal Insulation System
100' x 300' pre-engineered steel building with 14' eave height and 10,100 square feet of siding**

TABLE 4

	Uninsulated	Stayflex® System Thickness			
		1"	2"	3"	4"
Outside air film	0.17	0.17	0.17	0.17	0.17
Sheet metal	0.00	0.00	0.00	0.00	0.00
Insulation	0.00	6.50	13.00	19.50	26.00
Inside air film	0.61	0.61	0.61	0.61	0.61
Total R	0.78	7.28	13.78	20.28	26.78
BTU loss per hour*	1,799,287	192,280	102,456	68,772	51,930
Energy savings		1,607,007 89%	1,696,831 94%	1,730,515 96%	1,747,357 97%

* Calculations are based on insulated areas only and 70°F. indoor and 35°F. outdoor temperatures. Consideration is not given to slab loss, infiltration, air changes or any other areas of heat loss or gain.

BTU loss per hour = U Value x square feet of surface x temperature differential of interior and exterior in degrees Fahrenheit

Uninsulated: $U = 1/R = 1/0.78 = 1.282$
 BTU loss per hour = $1.282 \times 40,100 \times 35 = 1,799,287$ BTUs

1" Stayflex® System: $U = 1/7.28 = 0.137$
 BTU loss per hour = $0.137 \times 40,100 \times 35 = 192,280$ BTUs

2" Stayflex® System: $U = 1/13.78 = 0.073$
 BTU loss per hour = $0.073 \times 40,100 \times 35 = 102,456$ BTUs

3" Stayflex® System: $U = 1/20.28 = 0.049$
 BTU loss per hour = $0.049 \times 40,100 \times 35 = 68,772$ BTUs

4" Stayflex® System: $U = 1/26.78 = 0.037$
 BTU loss per hour = $0.037 \times 40,100 \times 35 = 51,930$ BTUs